



INSTRUCTION MANUAL (ATEX)

BExBG21D

Flameproof Xenon Beacon

For use in Flammable Gas and Dust Atmospheres

1) Introduction

The BExBG21D is a second generation flameproof beacon which are certified to the European Standards EN 50014: 1992, EN 50018: 1994, the Combustible Dust standard EN 50281-1-1: 1999 and meets the requirements of the ATEX directive 94/9/EC. The beacon produces synchronised visual warning signals and can be used in hazardous areas where potentially flammable gas and dust atmospheres may be present. The BExBG21D has can be used in Zone 1 and Zone 2 areas with gases in groups IIA, IIB and IIC and Temperature Classifications of T1, T2, T3 and T4 in an ambient temperature up to +55°C The beacon can also be used at an ambient temperature up to +70°C with a temperature classification of T3. The units can be used in Zone 21 and Zone 22 areas for combustible dusts and have an IP rating of IP 67 and a surface temperature rating of T135°C if the upper ambient temperature is restricted to +55°C or T200°C with an the upper ambient temperature of +70°C. The BExBG21D beacon has two xenon tubes and can produce three different flash patterns.

2) Marking

All units have a rating label, which carries the following important information:-

Unit Type No. BExBG21D

Input Voltage: DC Units 24V or 48V
AC Units 230V or 115V

Code: EEx d IIC T4 (Tamb. -50 to +55°C)
EEx d IIC T3 (Tamb. -50 to +70°C)

IP67 T200°C Ta ≤ +70°C
T135°C Ta ≤ +55°C

Certificate No. KEMA 00ATEX2006 X

Epsilon x:
Equipment Group and
Category:

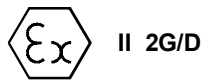

CE Marking
Notified Body No.

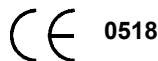

Warnings: DO NOT OPEN WHEN AN EXPLOSIVE
GAS OR DUST ATMOSPHERE IS PRESENT

COVER BOLTS CLASS A4-80

USE HEAT RESISTING CABLES AND CABLE GLANDS
(Rated 110°C) AT AMB. TEMPERATURES OVER 40°C

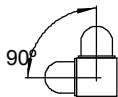

Year of Construction/ Serial No. i.e. 08 / 1DB72000001

3) Type Approval Standards

The beacon has an EC Type examination certificate issued by KEMA and have been approved to the following standards:-

EN 50014 : 1992 + prA1	General Requirements
EN 50018 : 1994 + prA1 + prA2 + prA3	Flameproof Enclosure 'd'
EN 50281-1-1 : 1999	Combustible Dust

4) Installation Requirements

The beacon must be installed in accordance with the latest issues of the relevant parts of the BS EN 60079 specifications or the equivalent IEC specifications – Selection, Installation and maintenance of electrical apparatus for use in potentially explosive atmospheres (other than mining applications or explosive processing and manufacture):-

BS EN 60079-14 : 1997	Electrical Installations in Hazardous Areas (other than mines)
BS EN 60079-10 : 1996	Classification of Hazardous Areas

The installation of the units must also be in accordance with any local codes that may apply and should only be carried out by a competent electrical engineer who has the necessary training.

5) Zones, Gas Group, Category, IP Rating and Temperature Classification

The BExBG21D beacon has been certified EEx d IIC T3 (Tamb. -50 to +70°C) and EEx d IIC T4 (Tamb. -50 to +55°C) for gas and IP67 T200°C Ta ≤ +70°C and T135°C Ta ≤ +55°C for dust. This means that the units can be installed in locations with the following conditions:-

Area Classification Gas:

Zone 1	Explosive gas air mixture likely to occur in normal operation.
Zone 2	Explosive gas air mixture not likely to occur, and if it does, it will only exist for a short time.

Gas Groupings:

Group IIA	Propane
Group IIB	Ethylene
Group IIC	Hydrogen and Acetylene

Temperature Classification:

T1	400° C	Amb. +70°C
T2	300° C	Amb. +70°C
T3	200° C	Amb. +70°C
T4	135° C	Amb. +55°C

Area Classification Dust:

Zone 21	Explosive dust air mixture likely to occur in normal operation.
Zone 22	Explosive dust air mixture not likely to occur, and if it does, it will only exist for a short time.

IP Rating: IP67 T200°C Ta ≤ +70°C
T135°C Ta ≤ +55°C

Equipment Category: 2G/D

Ambient Temperature Range: -50°C to +70°C
(T3 ≤ 55°C)

6) Beacon Location and Mounting

The location of the beacon should be made with due regard to the area over which the warning signal must be visible. They should only be fixed to services that can carry the weight of the unit.

SAFETY WARNING: The BExBG21D beacon must be mounted with their flashdome in a position between upright and 90° as shown.

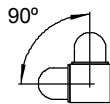

The beacons should be securely bolted to a suitable surface using the 7mm diameter boltholes in the stainless steel U shaped mounting bracket (see figure 1). The angle can then be adjusted as required but the mounting restrictions must be observed (see above). This can be achieved by loosening the two large bracket screws in the side of the unit, which allow adjustment in steps of 18°. On completion of the installation the two large bracket adjustment screws on the side of the unit must be fully tightened to ensure that the unit cannot move in service.

SAFETY WARNING: The flashdome guard must not be removed from the unit at any time.

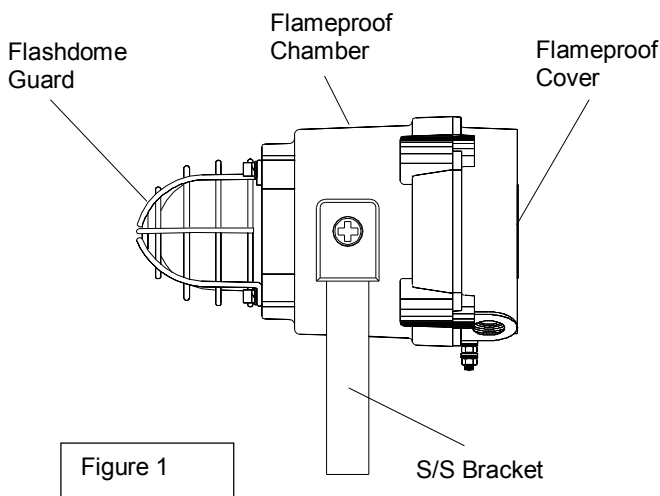

Figure 1

7) Access to the Flameproof Enclosure

In order to connect the electrical supply cables to the beacon it is necessary to remove the flameproof cover to gain access to the flameproof chamber. To achieve this remove the four M6 hexagon socket head screws (see figure 2) and withdraw the flameproof cover taking extreme care not to damage the flameproof joints in the process.

Note the four **M6 screws are Class A4-80 stainless steel and only screws of this category can be used on these beacons.** It is therefore important that these screws and their spring washers are kept in a safe place during installation.

On completion of the cable wiring installation the flameproof joints should be inspected to ensure that they are clean and that they have not been damaged during installation. Also check that the earth bonding wire between the two casting sections is secure and the 'O' ring seal is in place. When replacing the flameproof cover casting ensure that it is square with the flameproof chamber casting before inserting. Carefully push the cover in place allowing time for the air to be expelled. Only after the cover is fully in place should the four M6 Stainless Steel A4-80 cover bolts and their spring washer be inserted and tightened down. If the cover jams while it is being inserted, carefully remove it and try again. Never use the cover bolts to force the cover into position.

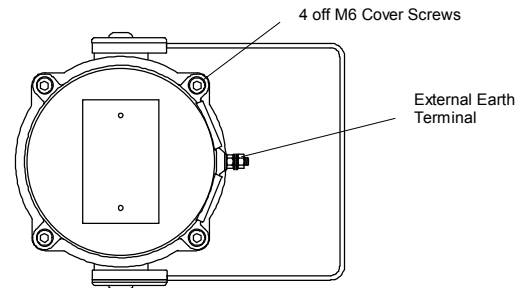

Figure 2

8) Power Supply Selection

It is important that a suitable power supply is used to run the beacon. The power supply selected must have the necessary capacity to provide the input current to all of the beacons connected to the system.

The following table shows the input current taken by the various units:-

Unit Type	Nominal I/P Voltage	Input Current	Max. I/P Volts
BExBG21D	24V DC	1.2A	28V
BExBG21D	48V DC	600mA	56V
BExBG21D	230V AC	280mA	253V
BExBG21D	115V AC	560mA	126.5V

The above table also shows the maximum voltages at which the beacons can be operated.

9) Cable Selection

When selecting the cable size consideration must be given to the input current that each unit draws (see table above), the number of beacons on the line and the length of the cable runs. The cable size selected must have the necessary capacity to provide the input current to all of the beacons connected to the line.

SAFETY WARNING: If the BExBG21D beacon is used at high ambient temperatures, i.e. over +40°C, then the cable entry temperature may exceed +70°C and therefore suitable heat resisting cables must be used, with a rated service temperature of at least 110°C.

10) Earthing

Both AC and DC beacon units must be connected to a good quality earth. The units are provided with internal and external earthing terminals which are both located on the terminal chamber section of the unit (see figures 2 and 3).

When using the external earth terminal a cable crimp lug must be used. The cable lug should be located between the two M5 stainless steel flat washers. The M5 stainless steel spring washer must be fixed between the outer flat washer and the M5 stainless steel nut to ensure that the cable lug is secured against loosening and twisting.

The internal earth bonding wire ensures that a good quality earth is maintained between the flameproof chamber casting and the flameproof cover casting.

BExBG21D Beacon Cover Internal View

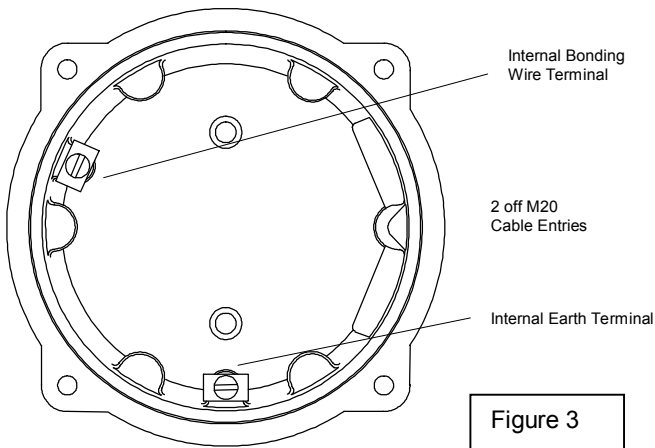

Figure 3

11) Cable Glands

The BExBG21D beacon has dual cable gland entries which have an M20 x1.5 entry thread as standard. Only cable glands approved for Ex 'd' applications can be used, which must be suitable for the type of cable being used and also meet the requirements of the Ex 'd' flameproof installation standard BS EN 60079-14 : 1997.

When only one cable entry is used the other one must be closed with an Ex 'd' flameproof blanking plug, which must be suitably approved for the installation requirements.

For combustible dust applications, the cable entry device and blanking elements shall be in type of explosion protection increased safety "e" or flameproof enclosure "d" and shall have an IP 6X rating according to EN 60529.

SAFETY WARNING: If the BExBG21D beacon is used at high ambient temperatures, i.e. over +40°C, then the cable entry temperature may exceed +70°C and therefore suitable heat resisting cable glands must be used, with a rated service temperature of at least 110°C.

12) Cable Connections

The cable connections are made into the terminal blocks on the electronic pcb assembly located in the flameproof enclosure. See section 7 of this manual for access to the flameproof enclosure. A four-way terminal block is provided on the AC beacons, with feeds both boards, therefore there are two live terminals and two neutral terminals so that both input and output wiring can be terminated if more than one beacon is being wired to a single supply. On the DC units there is a three-way terminal on each of the boards making up the electronics assembly. The terminal blocks are wired in parallel with each terminal having a +ve terminal a -ve terminal and an S2 second stage terminal. Therefore both input and output wiring can be terminated if more than one beacon is being wired to a single supply

BExBG21D DC 21 Joule Beacon

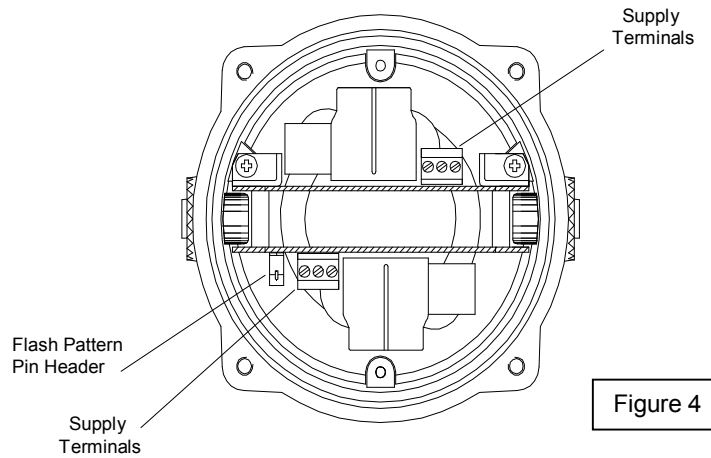

Figure 4

BExBG21D AC 21 Joule Beacon

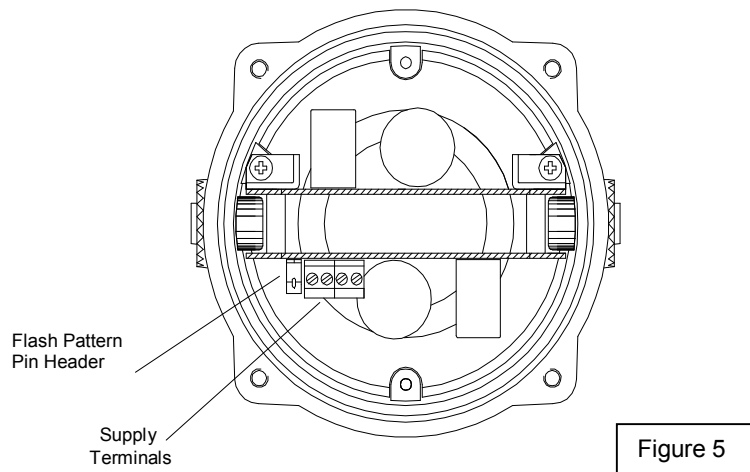

Figure 5

Wires having a cross sectional area of up to 2.5mm² can be connected to each terminal way. If an input and output wire is required a 2.5mm² wire can be connected to each terminal way. When connecting wires to the terminals great care should be taken to dress the wires so that when the cover is inserted into the chamber the wires do not exert excess pressure on the terminal blocks. This is particularly important when using cables with large cross sectional areas such as 2.5mm².

13) Synchronised Operation

All BExBG21D beacons that are connected to the same supply line will have synchronised flash patterns provided that they are set to the same flash pattern.

14) Flash Patterns

The BExBG21D beacons have two xenon tubes and can produce three different flash patterns as listed below. The flash patterns are set internally by the selection of pin headers. On the DC beacons the flash pattern set can be changed externally to produce a second stage by connecting terminal S2 to –ve supply line. The AC beacons do not have a second stage.

DC Beacons	Stage 2
Single Flash @ 1Hz (Both tubes flashing together)	AF
Alternate Flash @ 2Hz (Tubes flashing alternately)	SF
Double Strike @ 1Hz (One Tube flashing immediately after the other)	SF

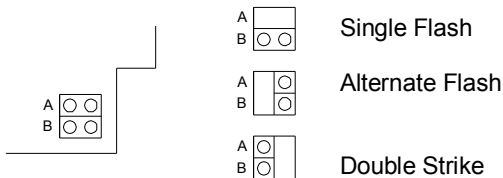

AC Beacons

Single Flash @ 1Hz (Both tubes flashing together)
Alternate Flash @ 2Hz (Tubes flashing alternately)
Double Strike @ 1Hz (One Tube flashing immediately after the other)

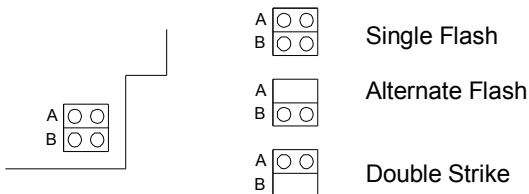

15) End of Line Monitoring (DC Units)

On the BExBG21D DC beacon, dc reverse line monitoring can be used if required. All DC beacons have a blocking diode fitted in their supply input lines. An end of line monitoring diode or an end of line monitoring resistor can be connected across the +ve and –ve terminals. If an end of line resistor is used it must have a minimum resistance value of 3k3 ohms and a minimum wattage of 0.5 watts or a minimum resistance value of 500 ohms and a minimum wattage of 2 watts.